

IMPORTANT INFORMATION: Product must be installed and used in strict conformance with NFPA Pamphlet 58 and/or NFPA Pamphlet 54 and all other codes, regulations and manufacturer recommendations.

Failure to follow these codes, regulations and recommendations could result in hazardous installation, bodily injury and/or death.

PRODUCT TRAINING SCHOOLS AVAILABLE. Contact a GEC customer service representative for more information.

WARNING: LP Gas is extremely flammable and explosive. Devices used for handling LP Gas and Anhydrous Ammonia must be installed and used in strict conformance with NFPA Pamphlet 58 and 54 and all other codes, regulations and manufacturer recommendations.

Ransome RH Series Direct-Fired LPG Vaporizers

Features

- Mechanical liquid inlet valve provides positive control of LP Gas liquid level on all RH 50, 80, and RH 120 sizes. Larger sizes use reliable float switch and electronic inlet valve to prevent liquid carryover.
- Millivolt-powered gas control system maintains consistent vapor temperature under changing load conditions.
- Modular design provides maximum capacity in a compact, rectangular unit.
- All sizes are capable of infinite turndown and maintain a ready supply of vapor from zero load to full capacity. At no load, only enough heat will be generated to maintain vapor temperature and prevent condensation.
- “E” option available for electronic ignition.

Models are available in a complete range of sizes from 50 GPH to 1,000 GPH propane capacity.

Standard models are built to conform with requirements of National Fire Protection Association pamphlet 58, American Society of Mechanical Engineers Section VIII and California Code of Regulations Title 8. All models are U.L. Factory Mutual System & Railroad Commission of Texas approved.



Part #	GPH Propane	Ft ³ /hr.	Millions of BTU/hr.	Burner Input BTU/hr.	Shipping Weight	Connections	
						Inlet	Outlet
RH 50	50	1,820	4.58	60,400	205 lbs.	3/4" NPT	1" NPT
RH 80	80	2,912	7.34	100,560	245 lbs.		
RH 120	120	4,368	11.0	135,920	285 lbs.		

Typical Vaporizer Installation - Principal Features

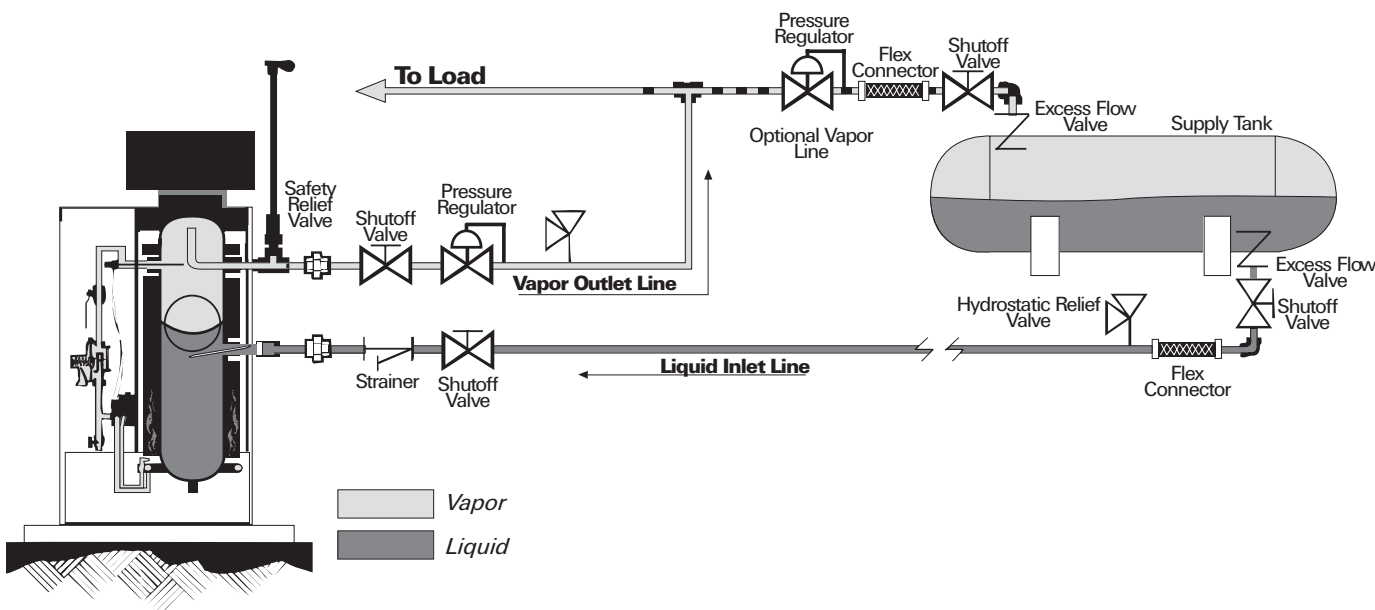

Algas Direct Gas-Fired LP Gas Vaporizer

The Direct Fired vaporizers are small (40 gph) to medium (120 gph) capacity vaporizers which are used on a wide variety of applications.

Features:

- Simple to Install - small & lightweight with only two piping connections required for installation.
- No electricity required.
- Steady gas supply over a broad temperature range.
- Sturdy all weather construction provides for maximum durability and resistance to the elements and eliminates the need for a shelter.
- Easy access to operating controls.
- Capacity control valve included on standard unit.
- Versatile modular construction allows additional vaporizers to be added to the system as demand grows.
- Operates at low temperatures.
- Capacity remains the same for propane or any LPG Supply.
- Complete with all operating and safety controls.
- Includes 3/4" inlet strainer with all models.
- Design pressure 250 psig.
- FM Approved.
- UL & ULC Approved. CRN's for all Canadian provinces.
- Standard unit has ASME Section I pressure vessel and is "S" code stamped.
- Standard unit is CE marked and the pressure vessel is PED stamped



40/40H

Part #	GPH Rating	MMBH Rating	Shipping Weight (lbs.)	Shipping Dimensions (in.)	Export Crating
40/40H	40	3.64	155	22"L x 21"W x 41"H	N/A
80/40H	80	7.28	220	22"L x 35"W x 41"H	N/A

Accessories

Part #	Description
41011	Auto-Reignitor, 9VDC Battery Operated
3-8683	Auto-Reignitor, 110/220VAC
1501-5016	Pipe-Away Adapter
80793	Economy Operation Kit

Algas-SDI's standard options for this product line are shown above. Non-standard options (not listed here) will be priced by Algas-SDI on a case by case basis, may involve longer lead times and may not be supported with documentation.



80/40H

Algas Electric LP/Propane Gas Vaporizer

The ZIMMER vaporizer is a compact wall-mountable electric LPG or Propane vaporizer.

Features:

- Simple, wall mount installation or tank mount with optional tank mounting kit.
- One model tolerates 100-240 volts AC or DC.
- Explosion-proof design allows for limited space installation.
- Self limiting heating elements require no additional electrical controls or thermostats.
- Metal to metal inverted valve seat prevents clogging.
- Light weight and easy to handle.
- Easy, low cost installation.
- Injection molded outer plastic shell with anti-static ground.
- Thermodynamic control valve modulates LPG or propane flow to ensure a minimum level of superheat.
- Reliable, very few parts to maintain or fail.
- Lower maintenance requirements than any other vaporizer.
- Replaceable heaters.
- Add more Zimmer vaporizers with no special parts needed.
- Non UL/CE marked units are supplied standard with factory explosion-proof electrical seal.
- UL/CUL/Demko Approved. CE and ATEX marked. Pressure Equipment Directive - SEP.



Part #	GPH Rating	KG/HR Rating	MMBH Rating	MMKcal/HR Rating	Shipping Weight (lbs.)	Shipping Dimensions (in.)
Z40P-UL/CE	20	40	1.82	0.448	60	35"L x 15"W x 12"H

NOTE: Capacity is 15 GPH@115V.

UL/CE model needs explosion proof electrical seal-off installed in the field.

Accessories

Part #	Description
80885	Wall Mount Kit (Includes: unistrut and hardware package for concrete, brick or wood frame wall mount.)
80892	Strainer & Piping Kit (Includes: 0-300 PSI gauge, angle valve, hydrostatic relief valve, ball valve, and 1/2" strainer.)
80890	Regulator & Gauge Kit (Includes: high temp REGO regulator X1584MN and 0-30 PSI gauge.)
80887*	Tank Mount Kit (Includes: bracket and all mounting hardware for horizontal tanks up to 51" diameter.)
80888**	Tank Mount Piping Kit (Includes: all inlet and outlet piping for connecting to 3/4" Check Lock valves.)
20556	Filtaire, F0.5
80895	Electrical Seal Kit, UL
80896	Electrical Seal Kit, ATEX (CE)

* Tank Mount Kit P/N 80887 includes all mechanical hardware to mount the ZIMMER directly on top of any horizontal tank up to 51" diameter. Larger diameter tanks can be easily accommodated by replacing the nylon coated galvanized wire rope with a longer section. Combine with 80888 for a complete installation kit with all components. Piping attaches directly to the bracket assembly for proper support. Powder coated bracket. Does not require welding.

** Tank Mount Piping Kit P/N 80888 includes: Check lock adapter, 0-300 PSI gauge, angle valve, hydrostatic relief valve, ball valve, and 1/2" strainer, high temp REGO regulator X1584MN, 0-30 PSI gauge, and pipe nipples and fittings to connect.

Algas-SDI's standard options for this product line are shown above. Non-standard options (not listed here) will be priced by Algas-SDI on a case by case basis, may involve longer lead times and may not be supported with documentation.

Sam Dick Electric Power XP Series Vaporizers

The Power[®] XP Series electric vaporizers safely vaporize LP Gas for commercial and industrial applications. Easy installation, low-cost maintenance and safe operation makes the Power Series ideal for hazardous locations like grain dryers.

Features

- Explosion proof configuration meets Class 1, Division 1, Group D as defined by NFPA pamphlet #70.
- UL stamped external relief valve: 250 PSIG (17.6 Kg/CM²).
- Easily accessible control housing allows simple maintenance.
- Compact footprint size of approximately 1 ft.².

Part #	GP	Kg/hr.	Million BTU/hr.
XP12.5	12.5	25	1.14
XP25	25	50	2.28
XP50	50	100	4.55
XP80	80	160	7.28
XP120	120	240	10.93
XP160	160	320	14.57

